

ASSEMBLY INSTRUCTION INSTRUCTIONS D'ASSEMBLAGE

MODEL / MODELE: C8359A-050 // C8389A-050
DRESSER & MIRROR /
COMMODE & MIROIR



**COMPLETE ASSEMBLY /
ASSEMBLAGE TERMINE**

PARTS IDENTIFICATION / IDENTIFICATION DE PIECES			
A.		MIRROR / MIROIR	1 PC / 1 PCE
B.		DRESSER / COMMODE	1 PC / 1 PCE
C.		MIRROR SUPPORT RAIL / RENFORT DU MIROIR	2 PCS / 2 PCES

HARDWARE LIST / QUINCAILLERIE				
1.		JCBC BOLT / BOULON JCBC	M6 x 40mm	8 PCS / 8 PCES
2.		SPRING WASHER / RONDELLE A RESSORT	M6	8 PCS / 8 PCES
3.		FLAT WASHER / RONDELLE PLATE	M6	8 PCS / 8 PCES
4.		ALLEN KEY / CLE ALLEN	M4	1 PC / 1 PCE

NOTE: You will also need a Philip screw driver (not provided) /
REMARQUE: un tournevis Phillips (non inclus) sera également nécessaire.

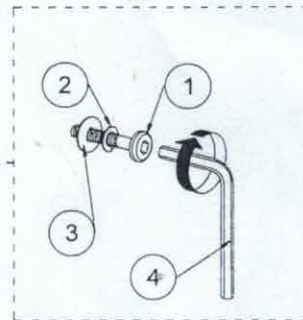
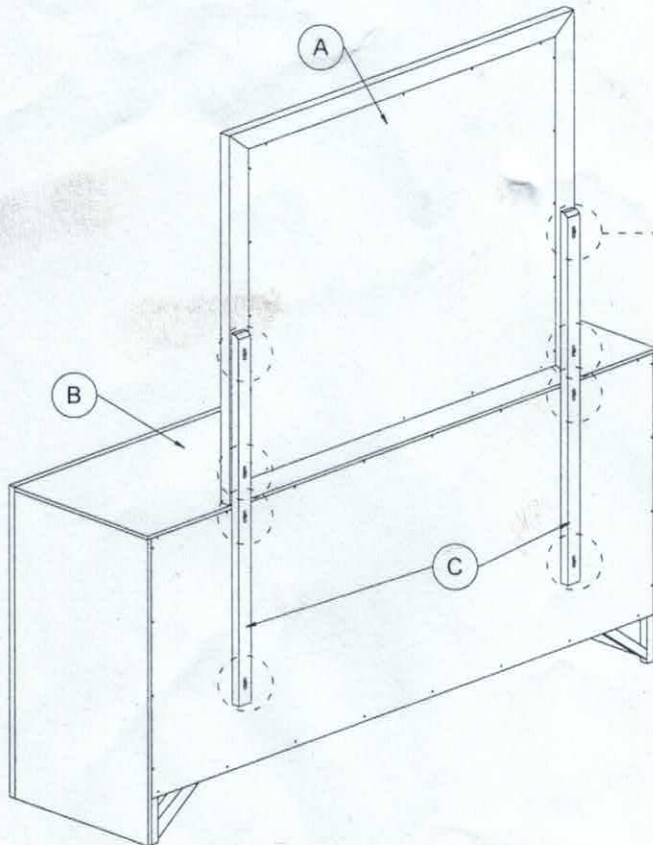

STEP 1 / ETAPE 1

Fix mirror on top of dresser. Insert JCBC bolt (1) into the holes at the mirror support. Tighten the support rail to the mirror & dresser with JCBC bolt (1) using Allen key (4). /
Fixer le miroir sur le commode. Insérer Boulon JCBC (1) dans les barres de soutien. Serrer les barres au miroir et au commode en utilisant les Boulons JCBC (1) à l'aide de la clé allen (4).

NOTE: MUST TIGHTEN SCREWS PERIODCALLY WITH USE SCREW WILL BECOME LOOSE CHECK TIGHTNESS OF ALL SCREW EVERY 6-8 WEEK. /
REMARQUE: RESERRER LES VIS REGULIEREMENT. A L'USAGE, LES VIS SE DESERRENT. VERIFIER QUE LES VIS SOIENT SERREES TOUTES LES 6-8 SEMAINES.